

VIBRATION MANAGEMENT CORPORATION

5930 THOMAS ROAD , HOUSTON , TEXAS 77041 , U.S.A

INTERNET ADDRESS: www.vimco.biz

MODEL*	THREAD SIZE (inches)	PART DIMENSIONS (inches)					MAX WORKING PRESSURE (psi)	TEMP. RANGE (°F)
		A	B	C	D	E		
DEU-GM05-BM05	1/2	1.41	0.83	0.75	2.79	0.82	300	-20 to 180 (up to 250°F with EPDM gasket)
DEU-GM07-BM07	3/4	1.61	1.04	0.77	2.85	1.07		
DEU-GM10-BM10	1	1.96	1.31	0.79	3.42	1.29		
DEU-GM12-BM12	1 1/4	2.36	1.65	0.84	3.68	1.57		
DEU-GM15-BM15	1 1/2	2.75	1.88	0.86	3.80	1.83		
DEU-GM20-BM20	2	3.14	2.33	0.88	4.22	2.35		

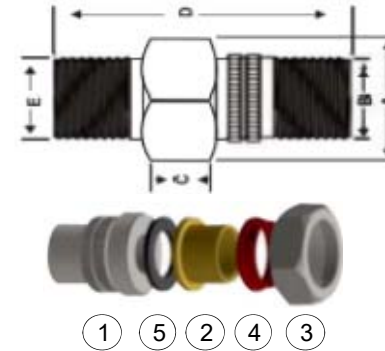

* Most commonly ordered materials+finishes are listed above. Refer "How to Order" section below for other material options.
Refer nomenclature submittal S-2700.20 for reducer model size combinations

APPLICATION

Designed to be installed between pipes made from dissimilar metals to prevent accelerated corrosion and deterioration in the piping system due to galvanic and stray current. DEU-xM-xM series feature male steel pipe thread to male brass pipe thread connections.

SPECIFICATIONS

- * Complies with Safe Drinking Water Act (SDWA)
- * Complies with ASSE 1079
- * Threaded ends comply with ASME B1.20.1 (NPT), ISO 7/1 (BSPT), ISO 228/1 (BSPP) or equivalent

FEATURES

- * **Lead Free*** compliant construction per Safe Drinking Water Act (SDWA)
**The wetted surface of this product contains less than 0.25% of lead by weight.*

MATERIALS

No.	Part	Description
1	Body	ASTM A105 forged steel
2	Tailpiece	Lead Free brass
3	Union nut	ASTM A105 forged steel
4	Insulator	Nylon
5	Gaskets	NBR (EPDM optional)

How to Order:

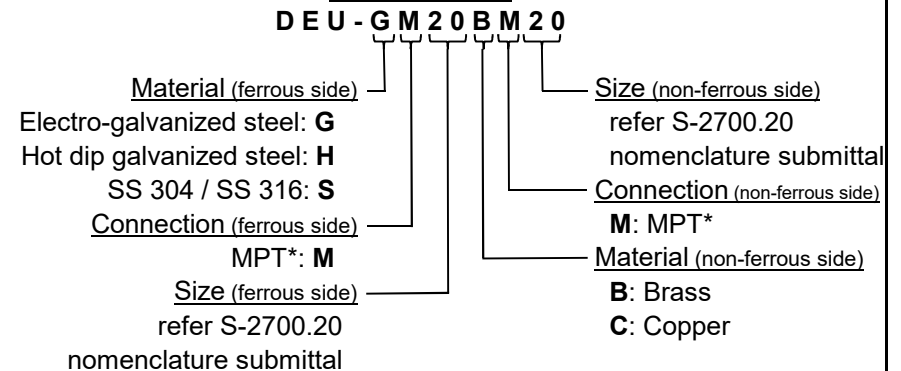

* specify thread standard (e.g. NPT, NPS, BSPT, BSPP) while ordering

Notes / Remarks :	Project :	DEU-xM-xM Di-Electric Union (Male - Male)	Title :	Drawing no. S-2700.25 Rev. 0
	Client :			
	Consultant :			
	Representative :			