

# VIBRATION MANAGEMENT CORPORATION

5930 THOMAS ROAD , HOUSTON , TEXAS 77041 , U.S.A

INTERNET ADDRESS: [www.vimco.biz](http://www.vimco.biz)

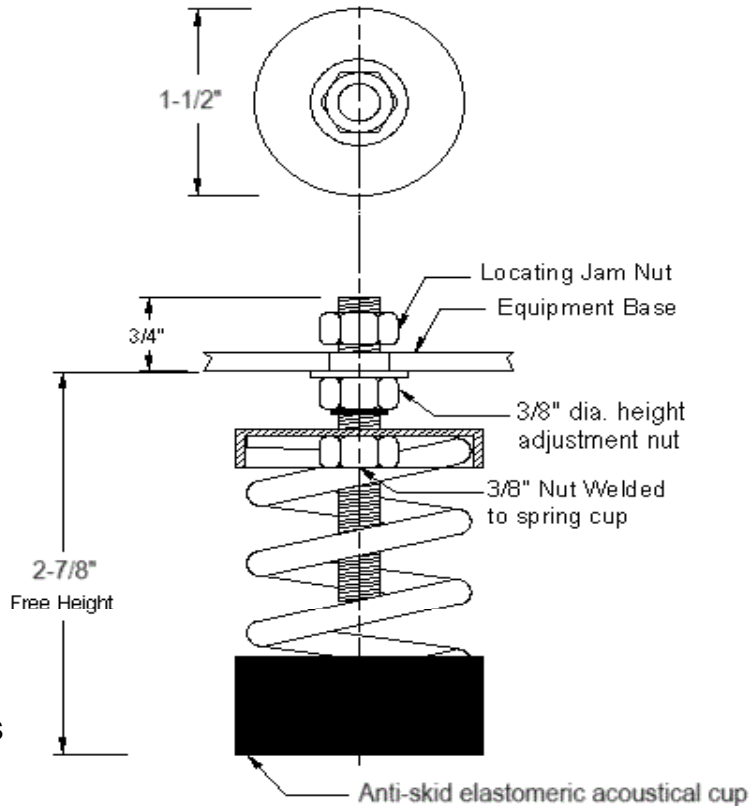
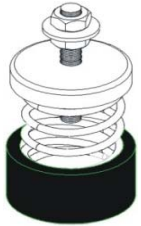

ISOLATOR MODEL	RATED LOAD (lbs)	SOLID LOAD (lbs)
BU-021	20	30
BU-022	44	66
BU-023	70	105
BU-024	100	150

### FEATURES

- \* Large diameter laterally stable springs
- \* Weld-free construction
- \* Anti-skid elastomeric acoustical cup
- \* Built-in leveling device
- \* Center mounting hole furnished as standard
- \* Spring elements color-coded for easy field verification

### NOTES

1. Springs have 50% additional travel to solid beyond rated load.
2. Isolators should be selected in the range of -30% to +25% of rated load.
3. Consult spring chart for isolator performance data.

Notes / Remarks :

Project :  
Client :  
Consultant :  
Representative :

Title :

**BU**  
Free-standing Spring Mount  
Rubber Cup Construction  
(0.75" deflection)

Drawing no. **S-2020.31**  
  
Rev. **0**